



Installer manual

SW24.T

24 Vdc control panel for swing gates

SW24.T

Contents:	Page
1 - Product features.....	1
2 - System type	1
3 - Description of the terminal blocks.....	2
4 - Connecting accessories.....	4
5 - Trimmer functions	6
6 - Button functions	6
7 - DIP-switch functions	6
8 - LED functions	7
9 - Gate travel calibration.....	8
10 - Remote control programming	10
11 - Battery operation.....	10

SW24.T

1 - Product features

Control panel for 24 Vdc swing gates with a rated power of 80 + 80W, equipped with an encoder interface to detect obstacles and control the speed, and an integrated 433 MHz receiver.

The control panel:

- can customize the slow-down distance and speed for both opening and closing
- has an obstacle detection system
- has LEDs input diagnostics and programming
- has a removable radio memory
- has an integrated receiver with a capacity of 200 remote controls (hard-coded or rolling-code)
- has current control to protect the electric motor

Technical specifications

Power supply	230 Vac
Motor supply voltage	24 Vdc
Maximum motor power	80 + 80 W
Flashing light output	24 Vdc 10 W max
Accessories power supply	24 Vdc 500 mA
Receiver memory	200 remote controls
Receiver frequency	433 MHz
Remote control encoding	Rolling code or hard coded
Fuse F1 (line protection)	ATO 15 A
Fuse F2 (accessory protection)	5x20 mm F3.15 A
Operating temperature	-10 to +50°C

Controllable actuators

Ref.	Description
EAM2	EKKO 300D linear operator 24 V 3 m 300 kg
EAM3	EKKO 400D linear operator 24 V 4 m 250 kg
EIM1	HIDDY 200D underground operator 24 V 2 m 200 kg

2 - System type

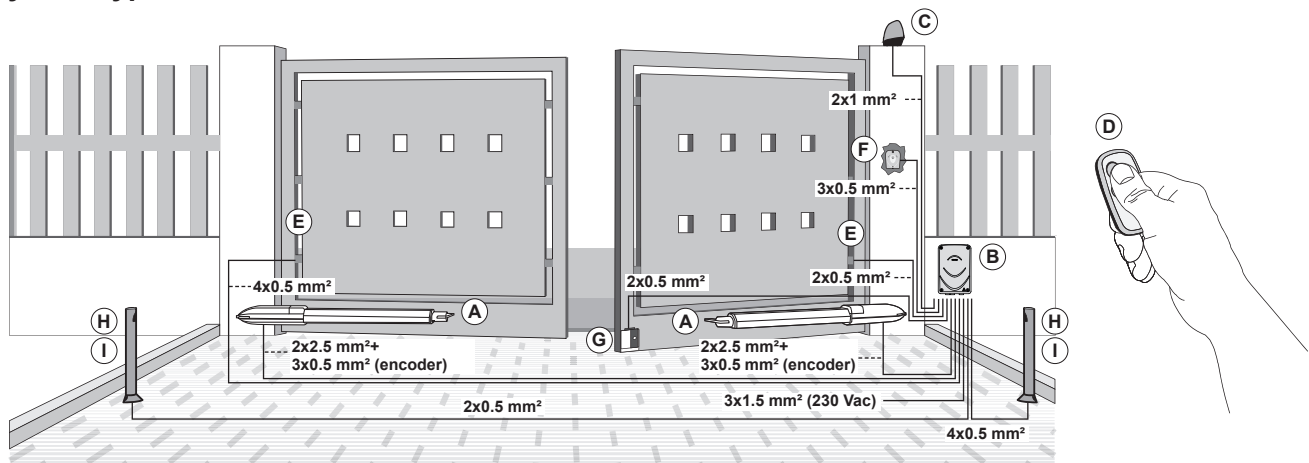

Components for implementing a complete system

Main Components		Accessories (optional)	
Description	Ref.	Description	Ref.
Actuator	A	Electric lock + cylinder	G
Control panel	B	Post-mounted photocells	H
Blinking	C	Posts	I
Remote control	D		
Wall-mounted photocells	E		
Key selector	F		

SW24.T

3 - Description of the terminal blocks

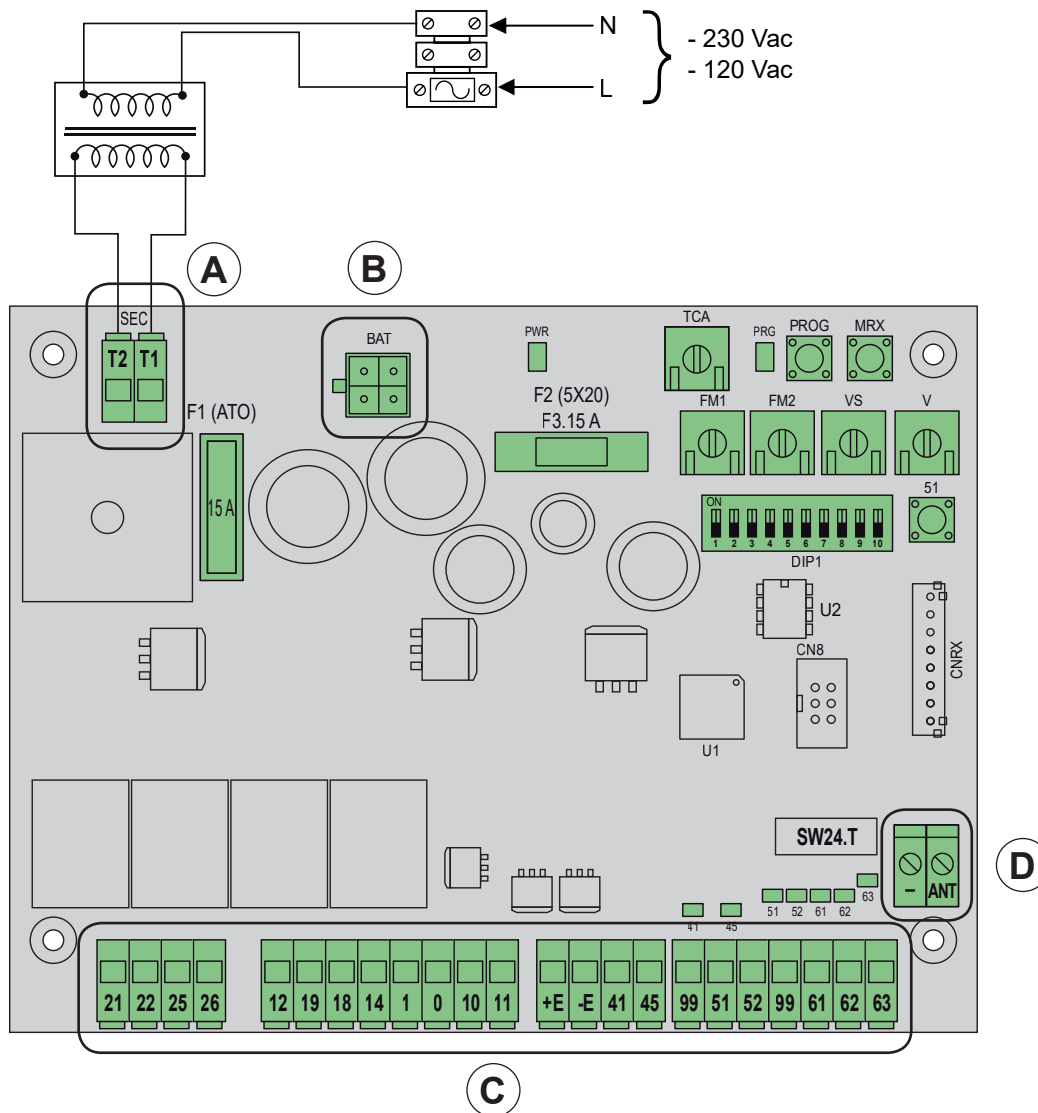

Terminal	Description	Rated data
T1	Transformer secondary connection	24 Vac
T2	Transformer secondary connection	
21	Opening motor 1	24 Vdc 80 W
22	Closing motor 1	
25	Opening motor 2	24 Vdc 80 W
26	Closing motor 2	
12	Auxiliary radio/courtesy light negative output	24 Vdc 120 mA
1	Accessories positive	
19	Electrical lock output	12 Vac 15 VA
18	Electrical lock output	
14	Gate open warning light negative output	24 Vdc 120 mA
1	Accessories positive	
1	Accessories positive	24 Vdc 300 mA
0	Accessories negative	
10	Flashing light negative	24 Vdc 15 W max
11	Flashing light positive	

Terminal	Description	Rated data
+E	Encoder power supply positive	12 Vdc
-E	Encoder power supply negative	
41	Motor 1 encoder signal	
45	Motor 2 encoder signal	
99	Common inputs	
51	Step-by-step (N.O.)	
52	Pedestrian (N.O.)	
99	Common inputs	
61	Stop (N.C.)	
62	Closing photocell (N.C.)	
63	Photocell (N.C.)	
-	Aerial earth	
ANT	Aerial signal	

SW24.T

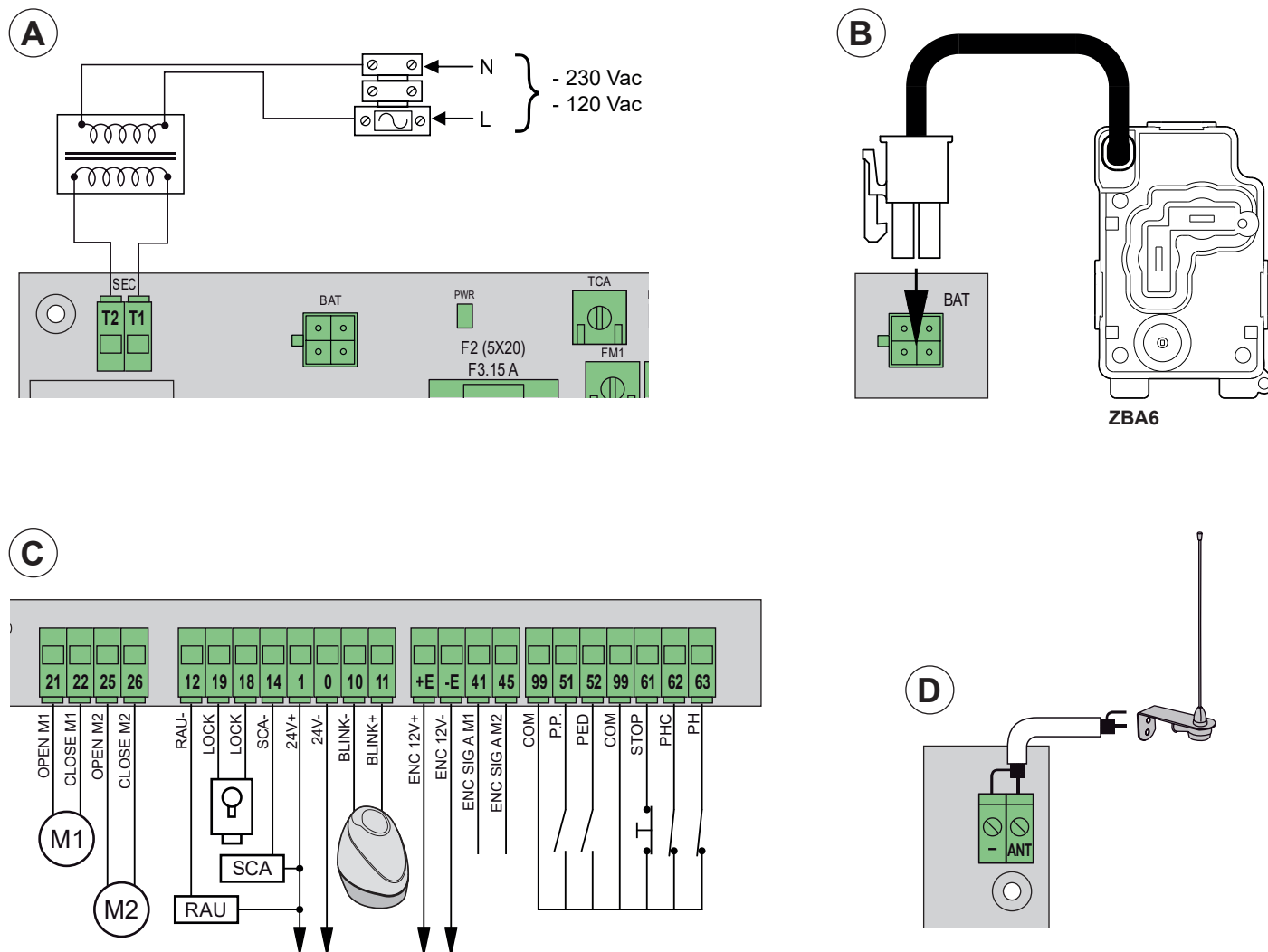

3.1 - Description of the output functions

0-1	<p>Accessories power supply: 24 Vdc output Functions according to the DIP 5 setting. DIP 5 = ON: Permanent power supply. DIP 5 = OFF: Photo-test active, the negative terminal (0) turns off for a few fractions of a second before the start of movement, so any accessories that require a permanent power supply (e.g. photocell receivers) must get the negative from an input common (terminal 99).</p>
10-11	<p>Flashing light: 24 Vdc output powered when the gate is moving.</p>
12-1	<p>Courtesy light (LCO) or Auxiliary Radio Output (RAU): 24 Vdc Courtesy Light or Auxiliary Radio output: With DIP 6 = OFF it is for a Courtesy Light: - it turns on when the gate is moving and remains on for 100 s after it has stopped. With DIP 6 = ON it is an Auxiliary Radio Output: - it turns on for 1 s on pressing the button that was saved on the remote control as the 2nd radio channel.</p>
14-1	<p>Gate Open Indicator Output (SCA): 24 Vdc output to indicate the gate movements: - it flashes slowly during opening - it is on continuously when the gate is open - it flashes fast during closing - it is on when the gate is closed</p>
18-19	<p>Electrical Lock Output: 12 Vac output to activate the electric lock when the gate starts to move.</p>

Note: using the photo-test requires the safety devices to be wired in a specific manner (par. 4.3).

SW24.T

3.2 - Description of the input functions

51	Step by step (N.O.): Sequential control input, to control the full gate travel. It operates with the following cycle: open-stop-close-stop.
52	Pedestrian (N.O.): Control input to open the gate for pedestrians (leaf 1 opens fully if it is double-leaf, it opens by 50% if it is single leaf).
61	Stop (N.C.): Stops the gate. If not used, jumper with the common (99).
62	Closing photocell - PHC (N.C.): When engaged, it allows opening if the gate is stationary, it does not trigger during opening, it does not allow closing if the gate is open and resets the automatic closing time when released, and it immediately reopens during closing. If not used, jumper with the common (99).
63	Photocell - PH (N.C.): Functions according to the DIP 4 setting. DIP 4 = OFF: It is active during both closing and opening; when engaged, it does not allow opening if the gate is stationary, it stops the movement during opening and continues when released, it does not allow closing if the gate is open and resets the automatic closing time when released, it stops the movement during closing and reopens when released. DIP 6 = ON: safety edge, N.C. voltage-free contact if DIP 7 = OFF, 8k2 resistive safety edge of DIP 7 = ON; when engaged, it does not allow opening if the gate is stationary, it disengages during opening, it does not allow closing if the gate is open and resets the automatic closing time when released, and it disengages during closing. If not used, jumper with the common (99) and set DIP 7 = OFF.

4 - Connecting accessories

4.1 - Key switch and control devices

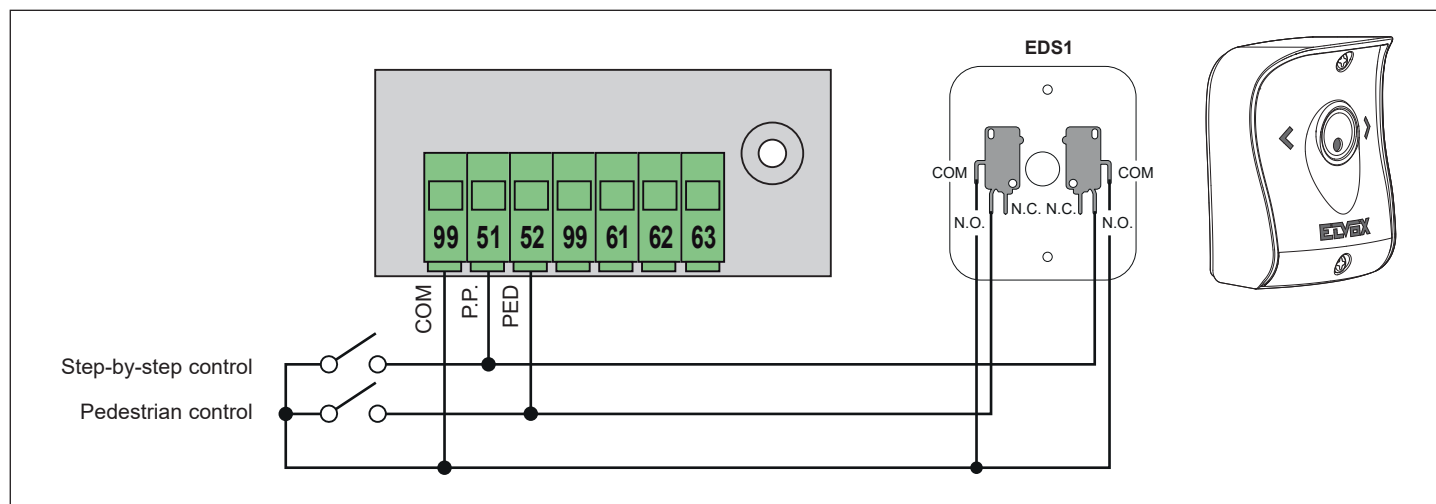

4.2 - Photocells and closing photocells

Normally closed contact (when the photocells are not engaged, the FCL and FOP LEDs must be on); if not used, jumper 62 to COM and 63 to COM; observe the polarity of the photocell power supply:

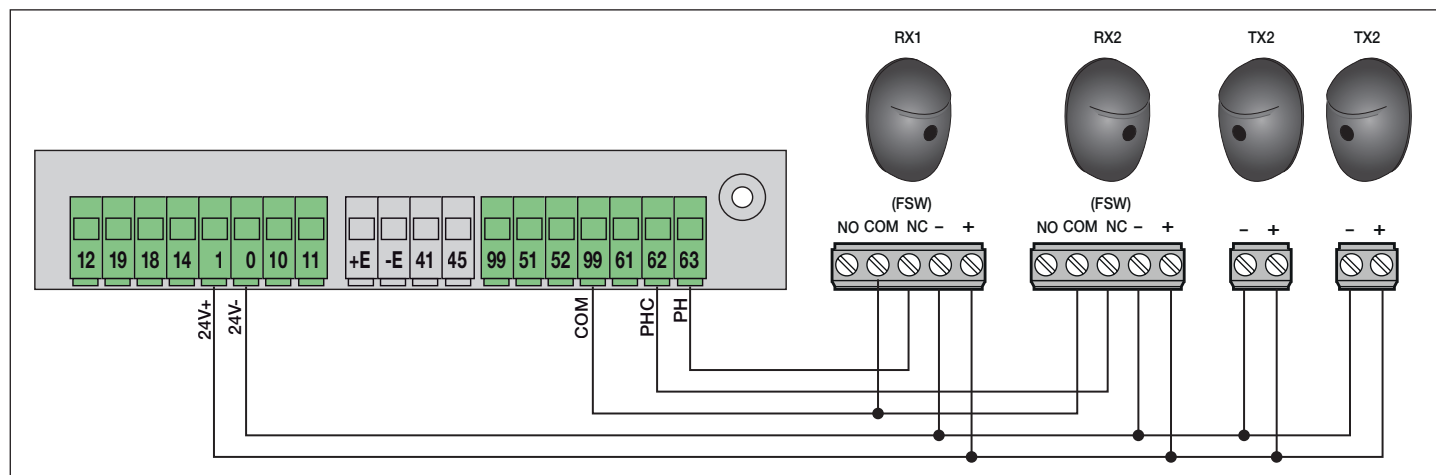

SW24.T

4.3 - Photocells and closing photocells with photo-test active (DIP 5 = ON)

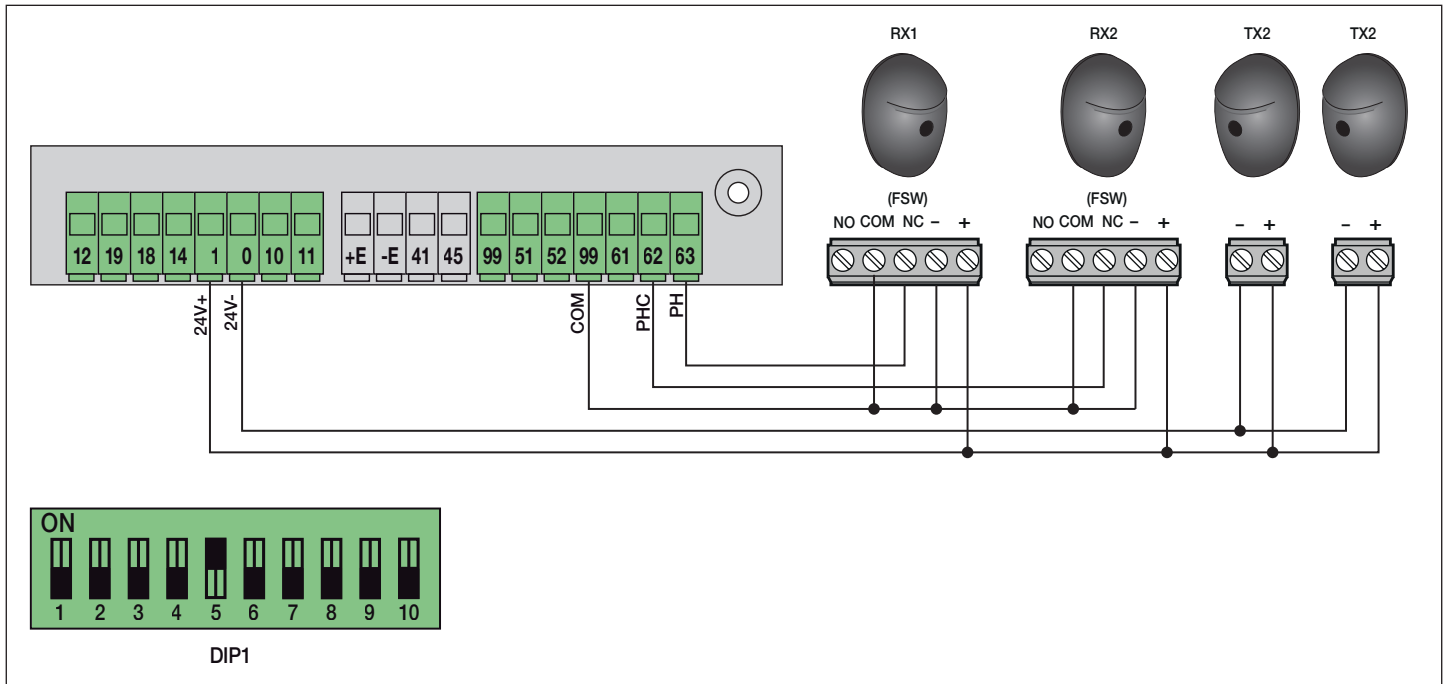

4.4 - Sensitive edge

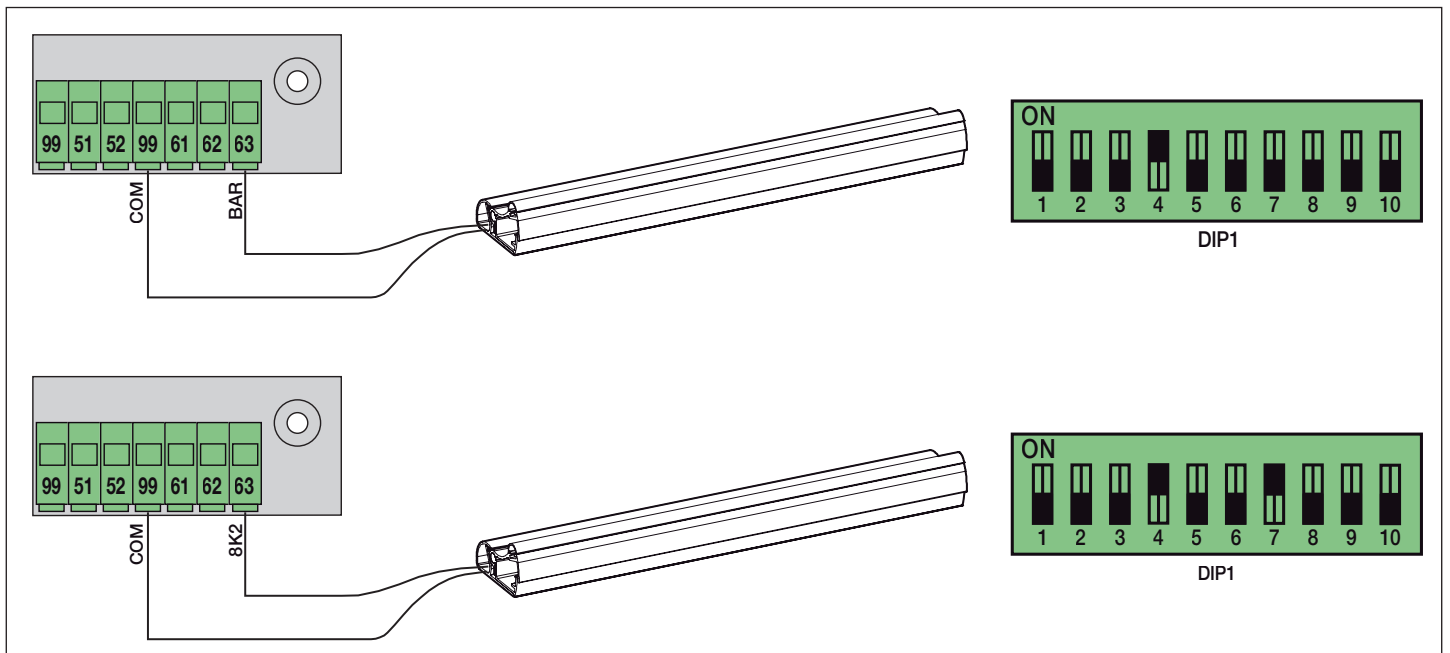

4.5 - Stop push-button

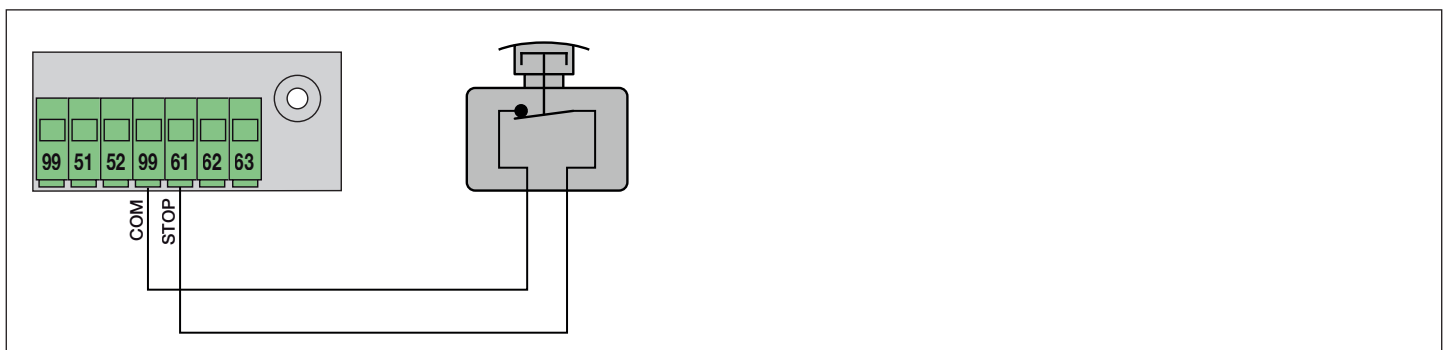

SW24.T

5 - Trimmer functions

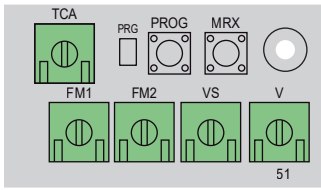

Trimmer	Description
TCA	Automatic re-closing time (adjustable from 2 to 120 seconds, turn the trimmer clockwise to increase the time)
FM1	Power of motor M1 (adjusts the torque of motor M1, turn the trimmer clockwise to increase the force)
FM2	Power of motor M2 (adjusts the torque of motor M2, turn the trimmer clockwise to increase the force)
VS	Slow speed (adjusts the slow speed of both motors, turn the trimmer clockwise to increase the speed)
V	Standard speed (adjusts the standard speed of both motors, turn the trimmer clockwise to increase the speed)

Note:

Adjusting the VS (slow speed) or V (standard speed) trimmer, will cause the PRG LED to flash fast RED to indicate that the speed settings have changed. Pressing button 51 opens and closes the gate fully to save the current consumption while moving at the new speeds; when fully closed, LED DL6 turns off, and the new values are saved.

The control panel is equipped with an obstacle detection system:

- if there is an obstacle while opening, the gate stops and closes for 1 second; automatic closing remains on.
- if there is an obstacle while closing, the gate stops and opens fully; automatic closing remains on. If the control panel detects 5 consecutive obstacles during closing, the gate will open and remain open, after which it is necessary to give a step-by-step command to close the gate at slow speed up to the mechanical stop.

6 - Button functions

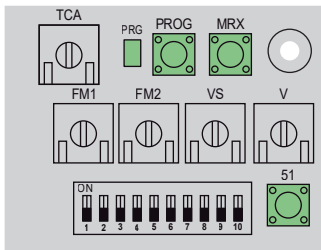

Button	Description
PROG	Button for programming the travel
MRX	Button for programming or deleting remote controls
51	Step-by-step command button

7 - DIP-switch functions

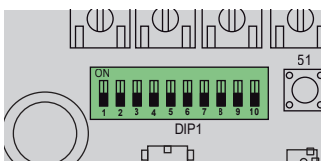

DIP	Function	Status	Description
DIP 1	Automatic closing	OFF	Automatic closing off
		ON	Automatic closing on
DIP 2	Apartment block	OFF	Apartment block on (while the gate is opening, you cannot stop the movement with a radio command or with inputs 51 (step-by-step) or 52 (pedestrian). With automatic closing on (DIP 1 = ON) and the gate open, an additional step-by-step command (terminal 51 or radio command) renews the pause time, and if input 51 remains engaged, the control panel suspends the pause count until the input is disengaged (for connecting any coils or a timer)
		ON	Apartment block off
DIP 3	Pre-flash	OFF	Pre-flashing off
		ON	Pre-flashing on, before the gate moves the flashing light comes on for 3 seconds
DIP 4	Input 63 type	OFF	Input 63 is for internal photocell
		ON	Input 63 is for safety edge (see DIP 7 for the safety edge type)
DIP 5	Photo test	OFF	Photo-test function off
		ON	Photo-test on: the negative accessory power supply terminal (0) turns off for a few fractions of a second before the start of movement, so any accessories that require a permanent power supply (e.g. photocell receivers) must get the negative power supply from an input common (terminal 99)
DIP 6	Output 12	OFF	Output 12 for Courtesy Light (LCO): each time the gate moves, the output remains on for 100 s. The remote control buttons saved on the second radio channel give a pedestrian command
		ON	Output 12 for Auxiliary Radio output: the remote control buttons saved on the second radio channel turn the output on for 1 s

SW24.T

DIP 7	Safety edge type	OFF	Safety edge with normally closed contact
		ON	Resistive safety edge, normally open contact with a parallel balancing resistor of 8.2 kOhm
DIP 8	Fast closing	OFF	Fast closing off
		ON	Fast closing function on: if the closing photocell (terminal 62) is engaged, the automatic closing time is set to 5 seconds when it is released
DIP 9	Hammering	OFF	Hammering function for the electric lock off
		ON	Hammering function for the electric lock on (facilitates releasing and engaging the electric lock)
DIP 10	Motor with/without encoder	OFF	The motors connected are equipped with encoders
		ON	The motors connected are not equipped with encoders

8 - LED functions

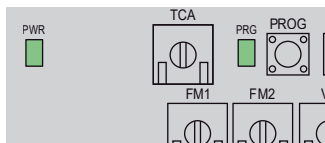

LED	Status	Description
PWR	OFF	No mains power supply
	ON	Mains power supply OK
PRG (or flashing light)	2 flashes	Photocell test failed (incorrect wiring or photocells engaged)
	3 flashes	Problem detected in the circuit that activates motor M1
	4 flashes	Problem detected in the circuit that activates motor M2
	5 flashes	Problem on encoder M1 (encoder M1 damaged or wired incorrectly)
	6 flashes	Problem on encoder M2 (encoder M2 damaged or wired incorrectly)
	7 flashes	Serious EEPROM error (EEPROM missing or damaged)
	8 flashes	Motor timeout (gear motor not engaged or damaged)
	9 flashes	Fuse F2 blown
	10 flashes	Motor M1 overcurrent error
	11 flashes	Motor M2 overcurrent error
	41	OFF
ON		When motor M1 is operating: it indicates that there is an encoder (it flashes very fast, depending on the motor rotation speed)
45	OFF	When motor M2 is operating: it indicates that the encoder is missing (not working) or motor M2 has no encoder
	ON	When motor M2 is operating: it indicates that there is an encoder (it flashes very fast, depending on the motor rotation speed)
51	OFF	Step-by-step input (term. 51) not engaged
	ON	Step-by-step input (term. 51) engaged
52	OFF	Pedestrian input (term. 52) not engaged
	ON	Pedestrian input (term. 52) engaged
61	OFF	Stop contact (term. 61) open (engaged)
	ON	Stop contact (term. 61) closed (not engaged)
62	OFF	Closing photocell (term. 62) engaged
	ON	Closing photocell (term. 62) not engaged
63	OFF	Photocell or safety edge (term. 63) open (engaged)
	ON	Photocell or safety edge (term. 63) closed (not engaged)

SW24.T

9 - Gate travel calibration

NOTE: To perform this procedure, the gate must be stationary.

CAUTION! THE SAFETY DEVICES ARE DISABLED DURING GATE TRAVEL CALIBRATION.

9.1 - Fast calibration, gear motor with encoder (DIP 10 = OFF)

(slows down at 30% of its travel, opening offset of 3 s, closing offset of 6 s)

No.	Press push-button	Step	Description
1	PROG	Procedure activation	Press the programming push-button PROG for at least 3 seconds, until the PRG LED starts flashing slowly, and then release it.
2	51	Close leaf M2	Press push-button 51: M2 closes at slow speed until it reaches the closed mechanical stop
3	-	Close leaf M1	M1 closes at slow speed until it reaches the closed mechanical stop
4	-	Open leaf M1	M1 closes at slow speed until it reaches the open mechanical stop
5	-	Open leaf M2	M2 closes at slow speed until it reaches the open mechanical stop
6	-	Close leaf M2	M2 closes at normal speed, slows down at 70% of its travel, and continues until it reaches the closed mechanical stop
7	-	Close leaf M1	M1 closes at normal speed, slows down at 70% of its travel, and continues until it reaches the closed mechanical stop
8	-	Complete cycle	The gate performs a complete opening and closing cycle with the default slow-down distance and offsets.
9	-	End of procedure	The PRG LED turns off. End of procedure.

Note: With this type of programming, the mechanical stops are necessary both when opening and closing, during programming and in normal operation. The steps with a grey background are for a double-leaf installation, and are not carried out for a single-leaf installation.

9.2 - Advanced calibration, gear motor with encoder (DIP 10 = OFF)

(slow-down and offsets programmed by the installer)

No.	Press push-button	Step	Description
1	PROG	Procedure activation	Press the programming push-button PROG and hold it down; the PRG LED will start flashing slowly; keep PROG pressed until the PRG LED flashes fast, and then release it.
2	51	Close leaf M2	Press push-button 51: M2 closes at slow speed until it reaches the closed mechanical stop
3	-	Close leaf M1	M1 closes at slow speed until it reaches the closed mechanical stop
4	-	Open leaf M1	M1 opens at normal speed
5	51	Set the slow-down point when opening M1	Press 51 to set the slow-down start point when opening leaf M1
6	51	Set the stopping point when opening M1	Press 51 to set the fully-open point of leaf M1, or wait for the leaf to reach the open mechanical stop
7	-	Open leaf M2	M2 opens at normal speed
8	51	Set the slow-down point when opening M2	Press 51 to set the slow-down start point when opening leaf M2
9	51	Set the stopping point when opening M2	Press 51 to set the fully-open point of leaf M2, or wait for the leaf to reach the open mechanical stop
10	-	Close leaf M2	M2 closes at normal speed
11	51	Set the slow-down point when closing M2	Press 51 to set the slow-down start point when closing leaf M2
12	-	Complete M2 closure	Leaf M2 continues until it reaches the closed mechanical stop
13	-	Close leaf M1	M1 closes at normal speed
14	51	Set the slow-down point when closing M1	Press 51 to set the slow-down start point when closing leaf M1
15	-	Complete M1 closure	Leaf M1 continues until it reaches the closed mechanical stop
16	-	Open leaf M1	Leaf M1 restarts opening at normal speed
17	51	Set the opening offset	Press 51 to set the opening offset time
18	-	Complete opening	M2 starts at normal speed and both leaves open fully
19	-	Close leaf M2	Leaf M2 restarts closing at normal speed
20	51	Set the closing offset	Press 51 to set the closing offset time
21	-	Complete closure	M1 starts at normal speed and both leaves close fully
22	-	End of procedure	The PRG LED turns off. End of procedure.

Note: With this type of programming, the mechanical stops are necessary both when closing during programming and in normal operation. The steps with a grey background are for a double-leaf installation, and are not carried out for a single-leaf installation.

SW24.T

9.3 - Fast calibration, gear motor without encoder (DIP 10 = ON)

(slows down at 30% of its travel, opening offset of 3 s, closing offset of 6 s)

No.	Press push-button	Step	Description
1	PROG	Procedure activation	Press the programming push-button PROG for at least 3 seconds, until the PRG LED starts flashing slowly, and then release it.
2	51	Close leaf M2	Press push-button 51: M2 closes at normal speed up to the closed mechanical stop
3	-	Close leaf M1	M1 closes at normal speed up to the closed mechanical stop
4	-	Open leaf M1	M1 opens at normal speed until it reaches the open mechanical stop
5	-	Open leaf M2	M2 opens at normal speed until it reaches the open mechanical stop
6	-	Close leaf M2	M2 closes at normal speed up to the closed mechanical stop
7	-	Close leaf M1	M1 closes at normal speed up to the closed mechanical stop
8	-	Complete cycle	The gate performs a complete opening and closing cycle with the default slow-down distance and offsets.
9	-	End of procedure	The PRG LED turns off. End of procedure.

Note: With this type of programming, the mechanical stops are necessary both when opening and closing, during programming and in normal operation. The steps with a grey background are for a double-leaf installation, and are not carried out for a single-leaf installation.

9.4 - Advanced calibration, gear motor without encoder (DIP 10 = ON)

(slow-down and offsets programmed by the installer)

No.	Press push-button	Step	Description
1	PROG	Procedure activation	Press the programming push-button PROG and hold it down; the PRG LED will start flashing slowly; keep PROG pressed until the PRG LED flashes fast, and then release it.
2	51	Close leaf M2	Press push-button 51: M2 closes at normal speed up to the closed mechanical stop
3	-	Close leaf M1	M1 closes at normal speed up to the closed mechanical stop
4	-	Open leaf M1	M1 opens at normal speed
5	51	Set the slow-down point when opening M1	Press 51 to set the slow-down start point when opening leaf M1
6	-	Complete M1 opening	Leaf M1 continues to the closed mechanical stop
7	-	Open leaf M2	M2 opens at normal speed
8	51	Set the slow-down point when opening M2	Press 51 to set the slow-down start point when opening leaf M2
9	-	Complete M2 opening	Leaf M2 continues to the closed mechanical stop
10	-	Close leaf M2	M2 closes at normal speed
11	51	Set the slow-down point when closing M2	Press 51 to set the slow-down start point when closing leaf M2
12	-	Complete M2 closure	Leaf M2 continues until it reaches the closed mechanical stop
13	-	Close leaf M1	M1 closes at normal speed
14	51	Set the slow-down point when closing M1	Press 51 to set the slow-down start point when closing leaf M1
15	-	Complete M1 closure	Leaf M1 continues until it reaches the closed mechanical stop
16	-	Open leaf M1	Leaf M1 restarts opening at normal speed
17	51	Set the opening offset	Press 51 to set the opening offset time
18	-	Complete opening	M2 starts at normal speed and both leaves open fully
19	-	Close leaf M2	Leaf M2 restarts closing at normal speed
20	51	Set the closing offset	Press 51 to set the closing offset time
21	-	Complete closure	M1 starts at normal speed and both leaves close fully
22	-	End of procedure	The PRG LED turns off. End of procedure.

Note: With this type of programming, the mechanical stops are necessary both when opening and closing, during programming and in normal operation. The steps with a grey background are for a double-leaf installation, and are not carried out for a single-leaf installation.

SW24.T**10 - Remote control programming**

Note: Remote control programming can only be done with the automatic gate system stationary

Step-by-step programming

No.	Press push-button	Signal PRG LED	Description
1	MRX	Off	Press the MRX push-button and hold it down until the green PRG LED starts flashing slowly
2	Remote control push-button	Slow flashing	Press the remote control push-button that you want to save
3	-	Fixed 1 s	Button of the saved remote control (new remote control)
		3 flashes	Memory full

Programming the second radio channel

No.	Press push-button	Signal PRG LED	Description
1	MRX	Off	Press the MRX push-button and hold it down until the green PRG LED starts flashing fast
2	Remote control push-button	Fast flashing	Press the remote control push-button that you want to save
3	-	Fixed 1 s	Button of the saved remote control (new remote control)
		3 flashes	Memory full

Deleting a remote control

No.	Press push-button	Signal PRG LED	Description
1	MRX	Off	Press the MRX push-button and hold it down until the green PRG LED starts flashing very fast
2	Remote control push-button	Very fast flashing	Press the button on the remote control to delete
3	-	Fixed 1 s	Deletion successful

Complete deletion of the receiver

No.	Press push-button	PRG LED indicator	Description
1	-	Off	Remove power from the control panel and disconnect any batteries
2	MRX	On continuously	Reapply power to the control panel without releasing the MRX button until the PRG LED turns off
3	-	Off	Receiver deleted completely

After deleting all of the remote controls, the first one saved configures the control panel to accept only rolling-code or hard-coded remote controls.

11 - Battery operation

When the control panel is battery powered, the motor speed is reduced to 15% of that used when powered from the mains. During battery operation, the PWR LED remains off, output 12 (Auxiliary Radio/Courtesy Light), output 14 (Gate Open Indicator) and output 10-11 (Flashing Light) are off, and output 0-1 (accessory power supply) are only on when the leaves are moving.

Note: During battery operation, the leaves move one at a time, both when opening and closing, without slowing down.

SW24.T**12 - Troubleshooting**

Problem	Cause	Solution
The automation system does not work	No mains supply	Check the power line switch
	Blown fuse	Replace the blown fuse with one of the same value
	Control and safety inputs not working	Check the diagnostic LEDs (61, 62 and 63 must be on)
You cannot save the remote controls	Safety devices open	61, 62 and 63 must be on
	Batteries of the remote control discharged	Replace the batteries
	Remote control not compatible with the first one saved	The first saved remote control configures the control panel to save only rolling-code or hard-coded remote controls
	Memory is full	Delete at least one remote control or add an external receiver (maximum capacity 200 remote controls)
As soon as the gate starts, it stops and reverses	The motor torque is insufficient	Use trimmer FM1 to increase the power for motor M1 and FM2 for motor M2
After a command, the flashing light flashes twice, but the gate fails to open	Photo test failed	Check the electrical wiring (see paragraph 4) and DIP 5. Check the alignment of the photocells
The flashing light does not work during movement	No mains power supply and motors are battery powered	Check the mains power supply
The gate detects an obstacle even when it is not there	The force trimmer is too low	Raise the force trimmer
	The gate mechanics are stiff	Service the gate
During slowdown, the gate stops and reverses	The slowdown speed is too low	Increase the value of trimmer VS
Movement of one of the 2 motors is reversed	The wiring is incorrect	Swap the power supply cables to the motor that moves in reverse
During calibration, motor M1 starts and stops after 1 second	Encoder 1 wiring reversed with encoder 2	Check the encoder wiring
With the electrical lock, motor M1 is not able to start opening or does not close completely	The electrical lock does not engage	Set DIP 9 to the ON position (hammering function on)

Regulatory compliance

Vimar SpA declares that this electronic device complies with EU directives 2014/53, 2006/42/CE, 2014/30/EU, 2014/35/EU. The full text of the declaration of EU compliance is on the product sheet available at the following Internet address: www.vimar.com.

REACH (EU) Regulation no. 1907/2006 – Art.33.

The product may contain traces of lead.



SW24.T installer EN 02 1904



VIMAR

Viale Vicenza 14
36063 Marostica VI - Italy
www.vimar.com